

C6 Quick Start Guide

Compu-Flow™

Compu-Flow™ Doppler Ultrasonic Flow Meter



COMPU-FLOW™

www.advancedflow.com

1-800-649-5331

C6 Quick Start Guide

INTRODUCTION:



When you need a reliable flow meter the Compu-Flow™ is the right choice. We have been manufacturing for the flow meter markets for the last 35 years.

The Compu-Flow™ Doppler ultrasonic flow meter provides an accurate and easy-to-use measuring system for high-solid fluid flow through pipes 1.00 inch to 999 inches (inside diameter). The Doppler flow meter is well suited for flow measurement applications such as sludges, slurries, aerated liquids, sewage, dredges, pulp, plastics, and activated sludges.



The Doppler flow meter features clamp-on transducers and a rugged NEMA 4X enclosure, and is a long-term, maintenance-free solution for your high-solid flow measurement requirements. Enclosure IP65, Sensor IP68.

INTRODUCTION:



Components of the Compu-Flow™ Doppler Ultrasonic Flow Meter System

A typical Doppler flow meter system is comprised of an electronics enclosure, with a display panel, and two clamp-on transducers.

ELECTRONICS ENCLOSURE AND DISPLAY PANEL

The display panel in the electronics enclosure features an easy-to-read LCD screen, a keypad, and LEDs to interface with the flow meter. The Doppler flow meter can be wall mounted for permanent installation or a portable option is also available.

TRANSDUCATORS AND CABLING

The Doppler flow meter is configured with clamp-on transducers. When installed, the sensors gather fluid flow data through a pipe and send this information to the system electronics. The electronics then convert, transmit, and display the received data.

The clamp-on transducers allow you to install the Doppler flow meter without shutting down flow and are ideal for smooth, clean pipe walls. The transducers are NEMA 6-rated and fully submersible. Contact [“Compu-Flow Systems Support”](#) for information on configuring your meter for continuous submersion.

THEORY OF OPERATION

The Compu-Flow™ Doppler ultrasonic flow meter measures flow velocity by sensing signals from reflective materials within a liquid and measuring the frequency shift due to the motion of these reflective materials. The Doppler effect states that the received frequency is a function of the transmitted frequency and the relative motion between transmitter and the receiver. The clamp-on transducers allow you to install the Doppler flow meter without shutting down flow and are ideal for smooth, clean pipe walls. The transducers are NEMA 6-rated and fully submersible.

The classic example of the Doppler effect is the train whistle increasing in pitch to the listener at the station as the train approaches, then decreasing in pitch as the train moves away from the station. To the person riding on the train, the pitch remains the same.

INTRODUCTION:

The increasing pitch is due to phase-front compression and the decreasing pitch is due to phase-front expansion. The Doppler flow meter uses this effect to measure the velocity of a liquid through a pipe wall.

Sonic Reflectors

The Doppler flow meter requires sonic reflectors in order to operate. These reflectors may consist of particles or air bubbles within the flow to be measured. Your readings may vary slightly with changes in concentration or size of these reflectors as well as the pipe condition and size.

Note: Glycerin is the only known industrial liquid today that is not sonically conductive.

The Doppler flow meter uses two similar transducers to sense flow in a pipe. These transducers are mounted on the outside of a pipe. This configuration presents no obstruction to flow, and will not cause associated pressure drops.

Accuracy

The Doppler flow meter output signal is linear (as opposed to square root), which means that accuracy is not a function of flow rate. Within certain application limits, the meter is ideal because it is not affected by changes of pressure within the process nor by changes of viscosity, temperature, specific gravity, sound velocity, or electrical conductivity.

Summary

The Doppler flow meter is a non-intrusive flow meter system which operates by sensing the frequency shifts of signals reflected from particles, air bubbles, or density differences within a liquid, producing a linear signal proportional to the flow of the liquid within the pipe.

- No pipe section is required to install the meter.
- The meter is not affected by changes in temperature, viscosity, specific gravity, or the speed of sound within the liquid.
- The liquid does not have to be electronically conductive.
- A minimum particle concentration of 35 ppm @ 40 micron of suspended solids or air bubbles is required.
- The reflector must have at least a 0.2% density difference than the liquid medium.
- For accurate volumetric measurement the pipe must be full at all times.
- The transducers are normally coupled to the outer pipe wall with greaser, sonic gel or epoxy.

INTRODUCTION:

- In order to obtain accurate measurements adequate upstream and downstream pipe runs are required. Recommended straight-run requirements from any disturbance of flow are 10 diameters upstream and 20 diameters downstream.

Assessing Particles or Air Bubbles

The ultrasonic beam from the transducer is transmitted through the pipe wall into the liquid. The particles, air bubbles suspended in the liquid, have to be large enough to act as reflectors to return the signal back to the transducer so that a measurement may be taken. It is important to understand that the ultrasonic beam from the Doppler flow meter does not penetrate air very well. A few bubbles will not affect flow meter performance, but too many bubbles may cause the meter to malfunction.

The flow to be measured must always have a sufficient number of sonic reflectors of ample size in order to provide reflection of the transmitted sound. If the reflectors do not have sufficient density difference they will neither rise nor fall in the solution but remain suspended. The specific gravity will also affect the ability of a particle to reflect sound. A good example of a reflector is a sand particle or an air bubble. A poor example is algae or onion skins.

Note: At a frequency of roughly 650 kHz, the minimum particle which can be sensed is 40 microns @ 35 parts per million (ppm) and at least 0.2% density difference from the liquid.

Assessing Pipe Material and Condition

Doppler flow meter performance is best maximized by using piping that is sonically conductive. The Doppler flow meter assumes that the path by which the ultrasonic beam enters the pipe and returns to the transducer is ultrasonically homogenous, which means that you must use your flow meter with pipes with non-porous smooth pipe walls. Concrete-lined pipes, old or crystallized cast iron pipes, hand-wrapped fiberglass pipe, and old piping with air inclusions do not exhibit the required homogeneity. Avoid using the Doppler flow meter for flow measurement on these pipes unless proper operation is proven by the manufacturer through demonstration.

Contact [“Compu-Flow Systems Support”](#) for more information on an alternate meter if your application is not suitable for the Doppler flow meter.

INSTALLATION:

Pipe Vibration

Moderate pipe vibration does not usually adversely affect the Doppler flow meter, since the vibration of the piping is at a significantly lower frequency than the ultrasonic beam used to measure flow. However, in situations where the transducer signal strength is low because of fluid, piping, or other environmental factors, measurement accuracy may be further decreased by pipe vibration. In these situations your display panel may register flow when there is none due to the vibration. If you can not bracket the pipe to reduce vibration, you may be able to rectify the problem by relocating the transducer to a pipe location with less vibration.

Assessing Flow Profile

STRAIGHT RUN REQUIREMENTS

As with other flow meters such as vortex or magnetic flow meters, the Doppler flow meter needs a well-developed flow profile to ensure accurate flow measurement. To assure a well-developed profile, choose a measurement point on a long run of pipe well away from elbows, valves, pumps, flanges, and other possible sources of turbulence.

The ideal placement of the Doppler flow meter is with 20 diameters of straight run upstream and 10 diameters of straight run downstream between the transducers and any disturbance of the flow. Most typical flow meter applications use 10 diameters of straight run upstream and 5 diameters downstream from any disturbance of the flow.

Fig. 1. Best recommended (✓) spots to install flow meters:

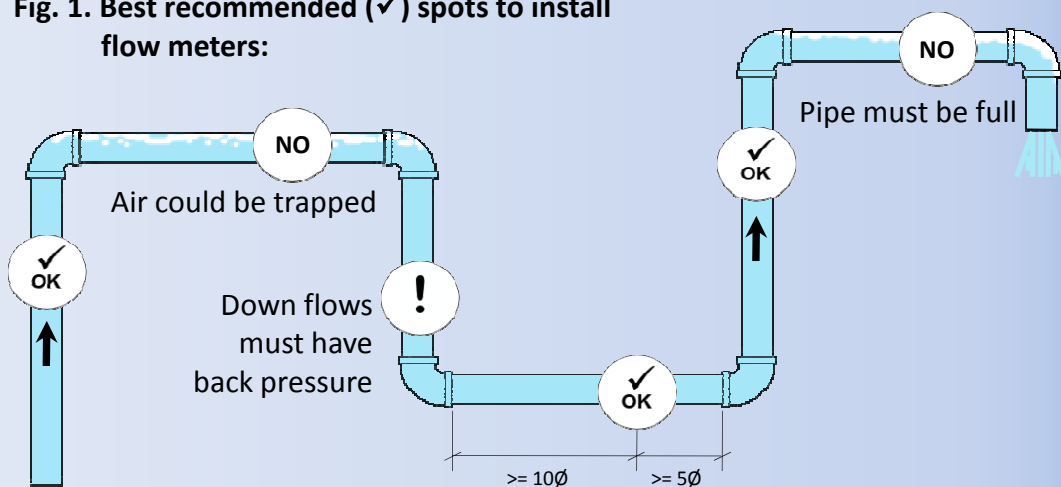

INSTALLATION:

However, when the measured fluid is too clean to provide the proper number of reflective particles, one may position the transducer near the pump or source of turbulence in such a manner as to obtain stable readings in a continuous flow full pipe situation. Using a transit time meter may be another viable option if the Doppler flow meter is not performing ideally. A point to remember is that turbulence is a non-linear function of flow, so turbulence can create reflected signals. Interpret readings near turbulent flows with caution.

Sources of turbulence are elbows, flanges, valves, orifices, wedges, pumps, pipe openings, and pipe irregularities (rust, corrosion, and buildup). Try to avoid vertical pipe runs (especially downhill pipe runs).

Table 1. Transducer distance from turbulence and reading accuracy

Upstream	Downstream	% Accuracy
20 Diameters	10 Diameters	±1% to 3% of full scale
10 Diameters	5 Diameters	±3% to 5% of full scale
5 Diameters	2 Diameters	±5% to 10% of full scale

Accuracy is dependant on flow profile, and is related to the percentage of sound reflectors and their size variation and distribution.

Figure 1 provides straight run examples.

INSTALLATION PROCEDURES

After you have performed the pre-install check and determined that the Doppler flow meter will work for your application, follow these steps to install your meter.

To Install the Compu-Flow™ Doppler Ultrasonic Flow Meter:

1. Mount and connect the transducers
2. Mount and connect power to the electronics enclosure (see page 10)
3. Turn on power to the electronics enclosure using the motherboard rear panel

INSTALLATION:

switch on the (front panel for portable) and follow display panel for meter set up (see “Programming” pages, for more information on configuring your meter for operation).

Mounting and Connecting the Transducers

The clamp-on transducers are NEMA 6-rated and fully submersible. (For continuous submersion secure sensors to pipe with approved epoxy.)

To Mount the Clamp-On Transducers to the Pipe:

1. Ensure the pipe surface is clean. Use sandpaper to remove all paint and scale from the pipe surface if necessary.
2. Apply sonic gel to the transducer lenses. For best results in most weather conditions and heat, use Dow Corning® High Vacuum Grease or the supplied Novagard® grease G661™.



Attention:

Always apply sonic gel to the transducer lenses before placing on the pipe. The sonic gel must be used to transmit the energy from the transducer crystals through the pipe wall and into the flow to be measured.

3. Place the transducers side by side between 7 o'clock and 10 o'clock on the pipe as shown in [Figure 2](#). Place the transducers flush to the pipe, facing the same direction. See [Figure 3](#) for an example.

Note: Be careful with transducer placement. Air bubbles near the top of the pipe or sediment on the bottom of the pipe can hinder successful flow readings. Place the transducers as shown in [Figure 2](#).

INSTALLATION:

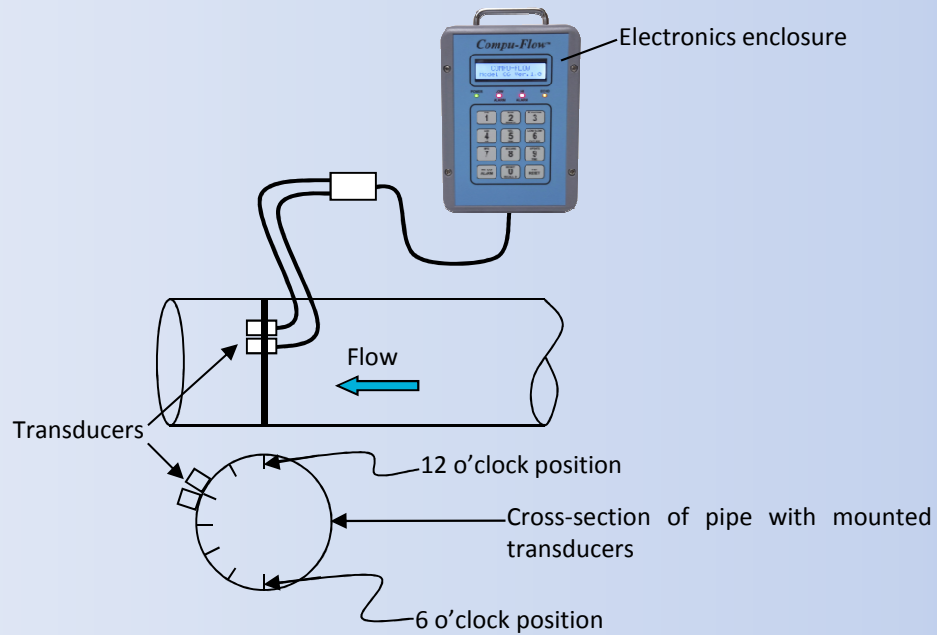

Figure 2. Clamp-on transducer placement

4. Use the supplied chain and bungee cord to strap the transducers in place, securing them tightly to the pipe. [Figure 3](#) provides an example of two properly mounted clamp-on transducers.

5. Small pipes below 2" do not permit side by side mounting.

Pipes 2"-1" diameter – mount sensors 90° apart

Pipes below 1" diameter – mount sensors 180° apart



Figure 3. Clamp-on transducers secured with a SS 1/2" gear clamp band

ELECTRICAL CONNECTIONS:

Transducer wiring:

If your Doppler sensors are not yet connected to the electronics control panel, open the panel, and use figure 4 as a guide to make the proper wiring for the 4 transducer cables: Black (-12VDC), Red (+12VDC), Green (Echo), White (Signal).

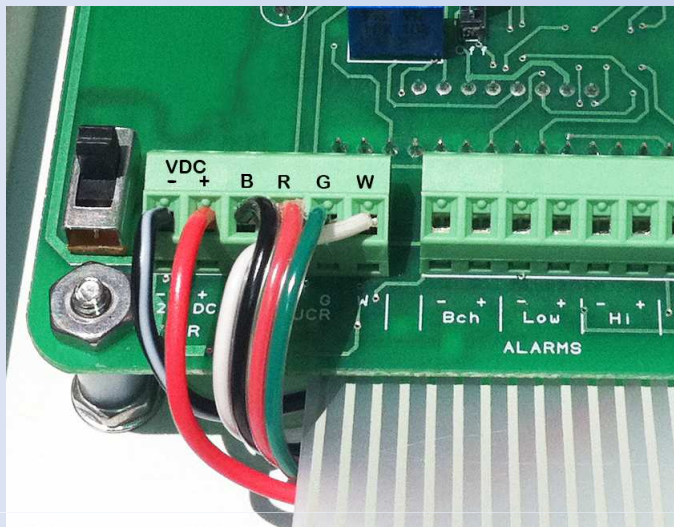

Figure 4.

To Connect Input Power to the Electronics Enclosure:

Note: You can either use AC power or DC/ battery power to operate your Doppler flow meter.

1. If you are using AC power: (wall module only)

- If not already connected, supply input power to the electronics enclosure by routing the power cable through the appropriate enclosure base opening.
- Use a Nema 4X cable gland and a cable backing nut to securely fasten the input power cable to the electronics enclosure.

Plug AC Power Module into the appropriate outlet.

ELECTRICAL CONNECTIONS:

2. If you are using DC/ battery power:

- If not already connected, supply input power to the electronics enclosure by routing the power cable through the appropriate opening .
- If needed, connect the DC power cable wires to the 12 VDC PWR section of the processor board using [Figure 4](#) as a guide.
- Use a Nema 4X cable gland and a cable backing nut to securely fasten the input power cable to the electronics enclosure.



Attention:

If you are switching from AC (DC) power to battery power, your battery may need charging.

PROGRAMMING



To Operate Your Doppler Flow Meter for the First Time:

1. Complete all the steps in “Installation” pages.
2. Turn on power and observe the display panel LCD. The display will show the model name and number of the unit.
3. Following the prompts presented by the display panel LCD, and making your entries using the keypad, configure your unit for operation for English or Metric.
 - The LCD screen displays SELECT RATE. Select the unit of measure for rate display: All rate selections may be displayed in seconds, minutes, hours, days. Time elements: (1=Sec 2=Min 3=Hr 4=Day)

Table 2. Rate selection - English

Key	Selection	Definition
1	FPS	Feet per second
2	GAL	Gallon
3	CF	Cubic feet
4	MG	Million Gallons
5	AF	Acre Feet
6	BL	Barrel 42 gal
7	MPS	Meters per second
8	LT	Liter
9	CM	Cubic meter

PROGRAMMING

If you select FPS, the flow meter will automatically begin measuring flow in feet per second. If you select keys 1 through 6, the LCD screen will ask that you enter your pipe ID in inches. If you select keys 7 through 9, the LCD screen will ask that you enter your pipe ID in millimeters.

After you enter your rate time element, the LCD screen will then display SELECT TOTALIZER. Select the unit of measure for totalizer display:

Table 3. Totalizer selection

Key	Selection	Definition
1	GAL	Gallons
2	CF	Cubic feet
3	MG	Millions of gallons
4	AF	Acre feet
5	BL	Barrels 42 gal
6	LT	Liters
7	CM	Cubic meters

After you enter your totalizer selection, the LCD screen will then display Enter Pipe ID. If you select keys 1 through 5, the LCD screen will ask that you enter your pipe ID in inches. If you select keys 6 through 7, the LCD screen will ask that you enter your pipe ID in millimeters.

Your flow meter is now configured to measure the flow parameters you have set. After you set the flow reading parameters you need for your system, you can secure these settings so they are saved in the event of power loss to the electronics enclosure.

Note: To clear the rate and totalizer parameters you have set, select “0” reset or switch the power off using the on/ off switch on the display panel. Until settings are saved using Key # 8, “Secure On”, the security switch, turning off power clears all previously set parameters. When you turn on power again, the LCD screen will prompt you to restart programming.

PROGRAMMING

To Save Your Programmed Flow Reading Settings Using the Secure Function:

1. Complete setting the flow reading parameters.
2. Press and hold key # 8 for 5 seconds until “Secure On” appears on the LCD display.

Note: If you need to change your programming, press and hold key # 8 “Secure” until “Secure Off” appears on the LCD display.

If you wish to further customize your flow meter system for operation in your process, continue on to [“Advanced Configuration Options”](#).

Advanced Configuration Options

The display panel keypad has a secondary menu for advanced configuration options (the keypad toggle menu). You may want to use this menu to set 4-20mA analog output, set up bar graph, select HI/LO alarm set points, and configure batch control. To access the secondary menu, press appropriate key until the display changes. To exit, press the key again.

- [Figure 5](#) provides a visual representation of the toggle menu.
- [Table 4](#) lists the advanced configuration options accessible from the display panel keypad.

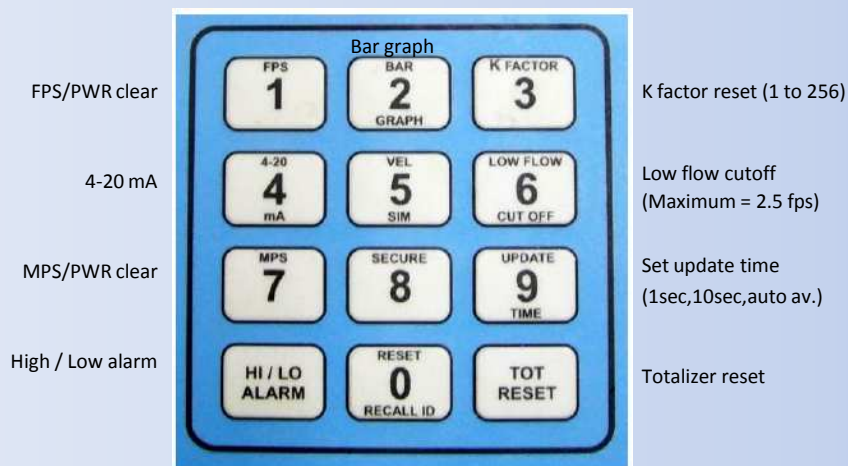

Figure 5. Display unit keypad

PROGRAMMING

Table 4. Keyboard Toggle Menu

Key	Selection	Functional Specifications
1	FPS	Feet per second/ clear pwr
2	Bar Graph	Analog 16 pt bar graph (n/a with batch)
3	K Factor	Select K factor while running
4	4-20 mA	Set up 4-20 mA analog output
5	Vel Sim	Velocity Simulator for systems test
6	Low Flow Cut Off	Set low flow cut off (maximum = 2.5 fps)
7	MPS	Meters per second/ clear pwr
8	Secure	Secure parameters On / Off
9	Update Time	Set update time (0 to 99 sec)
0	Reset / Recall Pipe ID	Recall pipe ID/ configure batch/ system reset
	HI / LO ALARM	Set up HI/LO limit alarms/ reset cursor
	TOT RESET	Reset totalizer while running/ reset cursor

Before Setting Advanced Parameters

The default setting for secondary keyboard functions is feet per second (fps), or meters per second (mps) if the flow meter is configured for metric units. Once the flow meter is operational and you wish to activate the analog bar graph, 4-20 mA output, batch control, high or low alarm, or low flow cut-off options, consult advanced parameter setting.

Sample parameter setting:

You have a velocity of 5 fps and you would like the 4-20 mA output to be 12 mA or 50% of scale. Push and hold the MA/4 key until the screen changes and then release the key. Enter a scale value of 10 fps via the keypad. The screen will automatically return the display to volumetric indication. The 4-20 mA output will read 12 mA at the terminal strip located on the right side of the main electronics circuit board. You may check your 4-20mA output setting via the bar graph.

PROGRAMMING

Note: Never adjust any of the potentiometers on the main processor board.
These settings are to be performed by authorized personnel only.

SETTING ADVANCED PARAMETERS

This section explains how to set advanced parameters using the keyboard on the front panel of the unit.

Bar Graph

To Set the Analog Bar Graph of Flow Rate: (n/a with batch)

1. Press the Bar Graph/2 key. Enter the desired full-scale flow rate in the indicated engineering unit.
2. To return to the rate and totalizer flow reading, press the Graph/2 key again.
3. To return to the graph, press the Graph/2 key again and select OK.

Batch Control

1. To configure batch control press "0" key and select Batch.
2. Select Enable and choose 1=Pulse, 2=Batch.
3. Select Batch volume in preselected engineering units.

K Factor (Correction Factor)

The default K Factor on the flow meter is set at 60 hZ/ fps for our Sensors. For nearly all applications, this default K Factor setting should be adequate. There are only a few circumstances that might merit adjusting the K Factor setting on your Electromagnetic flow meter. "K=100".

Analog Output:

To Set the Analog Output:

1. Press the MA/4 key Enter the full scale preselected engineering unit.
2. After the output level has been set, the LCD screen will return to the rate and totalizer flow reading.

PROGRAMMING

Low Flow Cutoff

To Set the Low Flow Cutoff:

1. Press the FPS/1 or MPS/7 key to obtain the current reading in feet per second or meters per second. Press the key again to return to the flow reading parameters previously shown.
2. Press the LFC/6 key. Enter the cutoff in feet per second or meters per second. If you enter a parameter that is too high, the LCD screen will display the maximum allowable cutoff setting and then will return to the prompt for cutoff in feet per second.
3. After the low flow cutoff is set, the LCD screen will return to the rate and totalizer flow reading.

Meters per Second/ Power Clear

To Read Meters Per Second:

1. Press the MPS/7 key. The LCD will show the flow reading in meters per second on the upper line of the LCD screen, replacing the rate parameter previously on the screen. The totalizer reading remains the same parameter.
2. To return to the previous flow rate, press the MPS/7 key again.

Update Time

To Set Update Time:

1. Press the UT/9 key. To enter the selection screen.
1 = 1 sec 2 = 10 sec 3 = auto; "Auto" mode will update every second when the velocity change is >5%. When the flow stabilizes to < 5% change, the update time resets to a 10 second running average.
2. Enter the update time in 1 second, 10 seconds , or Auto.
3. After the update time is set, the LCD screen will return to the rate and totalizer flow reading.

PROGRAMMING

Hi/Low Alarms

To Set the High/ Low Alarms:

1. Press the HI/LO ALARM key. Select Hi, Lo, or Both.
You may change the alarms one at a time without affecting anything else.
2. Next enter the high limit alarm in your preselected engineering unit.
3. Now enter the low limit alarm in your preselected engineering unit.
4. After the high and low alarm parameters are set, the LCD screen will return to the rate and totalizer flow reading.

Totalizer Reset

To Reset the Totalizer While the Unit is Running:

1. Press the TOT RESET key. The totalizer reading will return to zero.
2. The meter will begin taking totalizer readings from zero.
The rate reading remains unchanged.

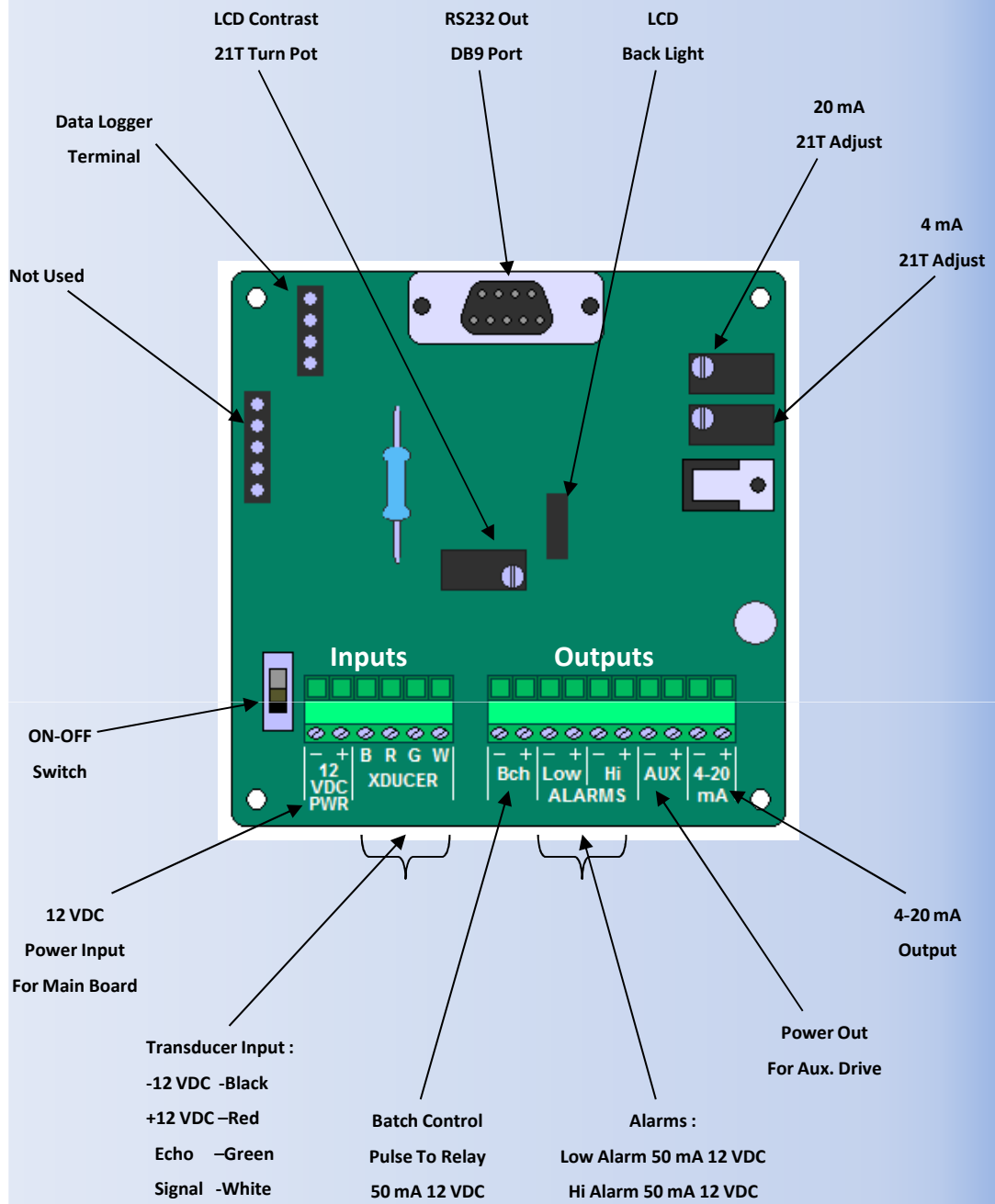

Fig. 6. Main electronics board connections

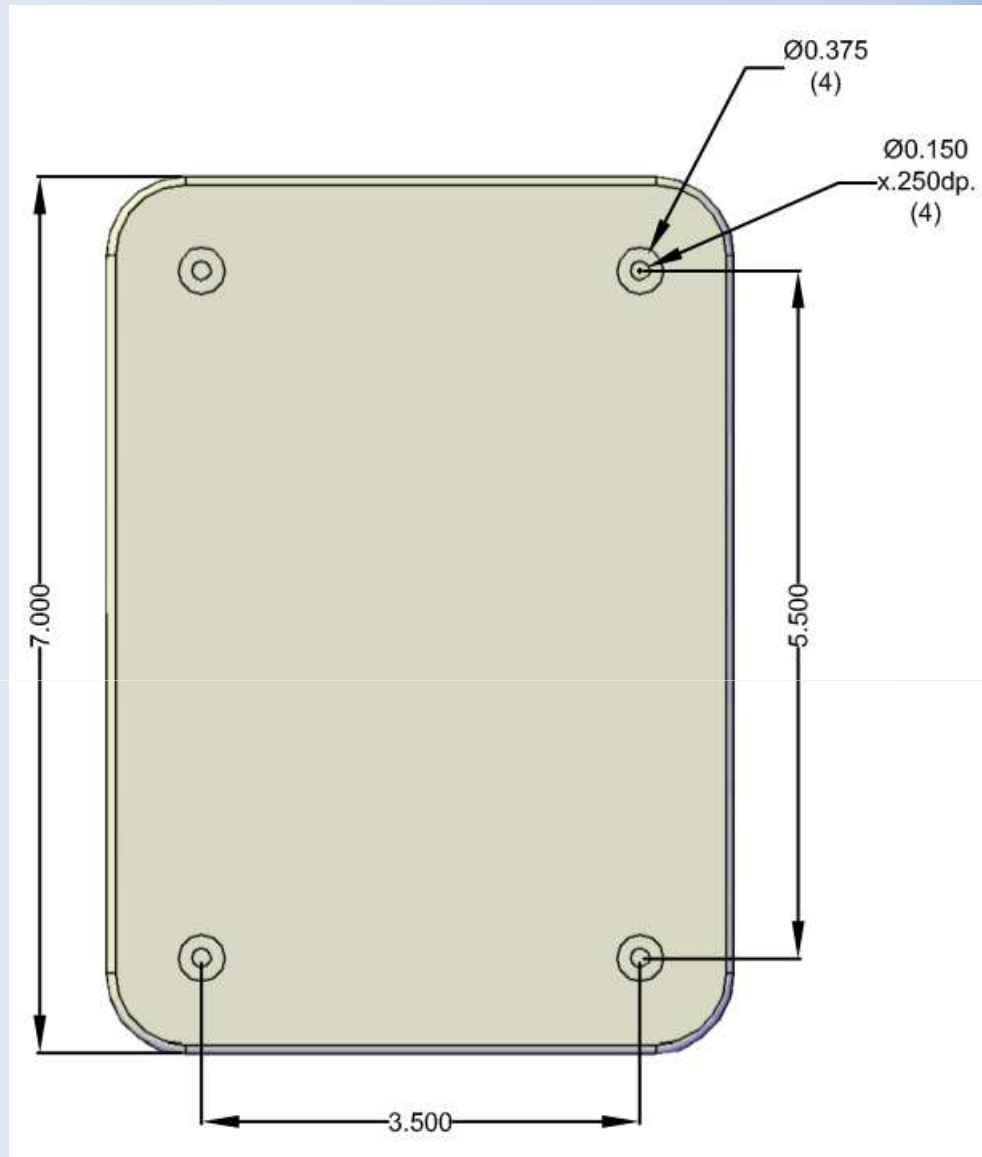

Figure 7. Wall mounting of the electronics enclosure

COMPU-FLOW™
C6_CLTV6.4_HP Spec Sheet

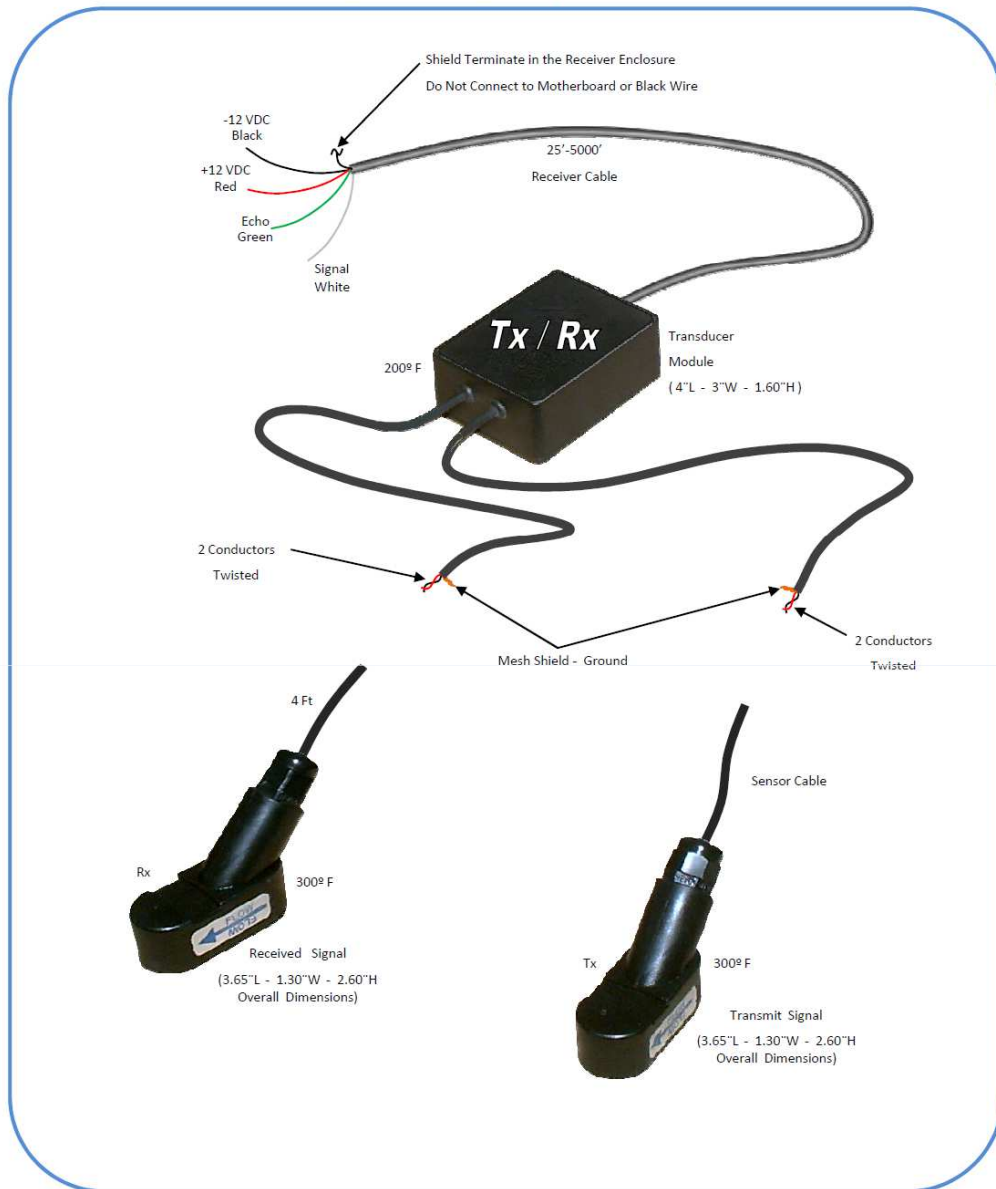

Figure 8. C6_CLTV6.4_HP Spec Sheet

Table 5. Functional specifications

Description	Specification
Alarm output	AC: Separate Power module required for relay/ output Alarms & Batch
RS232 output	RS232 via DB9 & USB ports 9300 baud rate Terminal Emulation Software (HyperTerminal for Windows/ ZTerm for Mac)
Data Logger output	1-32 GB USB Flash drive USB board mount or remote cable
Power failure backup	Allows the electronics assembly to retain all parameter information and current totalizer value for 99 yrs
Standard interface	Specification
LCD display	2-line, 16 characters per line, high resolution, backlit
LED indicators	· Yellow: Echo signal received · Red: High alarm or low alarm activated · Green: Power available
Keypad	12 keys, tactile feedback Note: Keypad lockout via front panel keyboard; see "To Save Your Programmed Flow Reading Settings:" on page 16 and figure 1
Display panel	Rate selection, totalizer selection, K factor selection, analog output, low flow cutoff, update time (damping), high/ low alarm, fps, or mps selection, totalizer reset, etc
Output setting function	4-20mA output scaling (from keypad) in selected engineering units
Alarm setting function	High and low alarms set points (entered in engineering units)
Rate indication	4-digit LCD, velocity or volume (user selectable) English units: feet per second (fps), gallons (Gal), cubic feet (CF), and million gallons (MG), SMHD Metric units: meters (M), liters (LT), and cubic meters (CM), SMHD Note: Gallons refers to U.S. gallons, BBL=42gallon SMHD= Seconds, Minutes, Hours, Days
Totalizer indication	12-digit LCD English units: gallons, cubic feet, acre feet, barrels, and millions of gallons Metric units: liters and cubic meters Note: Gallons refers to U.S. gallons. BBL=42gallon
Update time (damping)	Entered from keypad 1sec – 10sec – Auto Running Avg (75%=1sec)
Low flow cutoff	0 fps to 2.5 fps (0 mps to 0.76 mps), entered from keypad
K factor	A value of 1 to 256, entered from keypad depending upon sensor type. The default for Doppler is 60 Hz. For the Mag Meter is 100 Hz.
Totalizer reset	Totalizer reset can be manually reset to zero from keypad
Key "#" function	Reset flashing cursor
"0" Key function	Resume- Reset ; Pipe ID- Batch
"8" Key function	Secure On/Secure Off
"5" Key test function	Test velocity simulator on/off
"2" Key function	Setup 16 point Bar Graph tracks 4/20mA output (n/a with Batch)